

**Gear Type Flow Meter  
VC**

# Construction and principle of operation

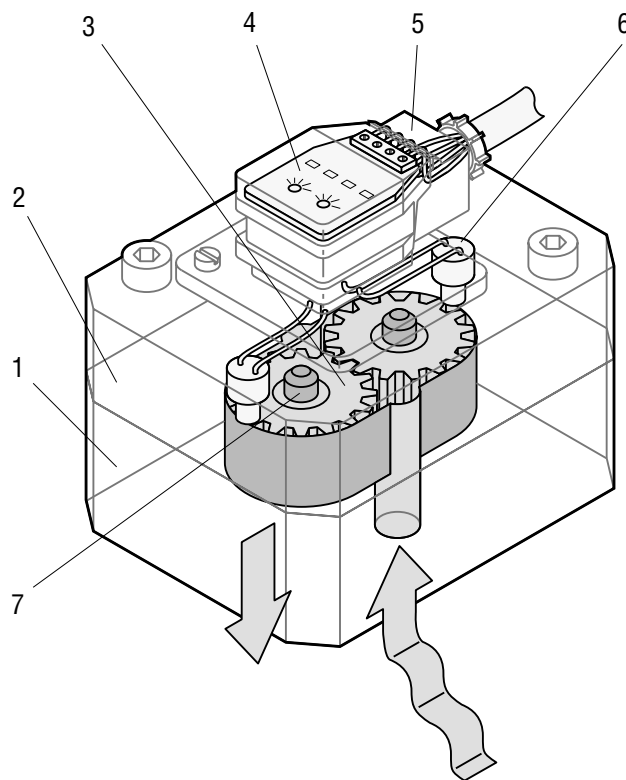

## Construction

- 1 Housing
- 2 Cover
- 3 Gear
- 4 Preamplifier
- 5 Connector
- 6 Sensor
- 7 Bearing assembly

## Principle of operation

- The measuring gears are driven by the liquid flow on the principle of a gear motor.
- The gears run without contact in the measuring chamber. The bearing elements are low-friction ball or plain bearings.
- The movement of the gears is sampled without contact by means of two sensors located in the cover. Between sensor compartment and measuring chamber is located a pressure-resistant, non-magnetic separator plate.
- When the measuring mechanism rotates by one tooth pitch, the sensor emits a signal which corresponds to the geometrical tooth volume  $V_{gz}$ .
- The signal is converted into a square-wave signal by the preamplifier.
- The two-channel sampling permits better resolution as well as recognition of the flow direction.

## Product features

- Optimized for individual applications because the series have been rendered media-specific by means of differing clearances, bearing variants and materials.
- Wide measuring ranges with sizes graduated to meet specific requirements.
- Measurement independent of viscosity within the specified ranges.
- Low pressure drop
- High-response measurement
- High operating pressure
- Low noise emission
- High-precision measurement with outstanding reproducibility
- Temperature-independent output signals over a wide temperature range
- High degree of accuracy, even with low flow rates at the bottom end of the measuring range
- High operating reliability of the electronics
- Easy to use terminal of the preamplifier
- Operating indication of the electronic
- Sensor system and preamplifier in EMC-compatible design
- Explosion-proof version available for all volume counters

## Typical applications

Application	Medium	Version	Series
Flow rate measurement (hydraulic test stand)	oil, brake fluid, skydrol, diesel lubricating low viscosity	cast iron ball bearings minimal clearances	1
Oil metering (metering plant)	gear oil lubricating medium viscosity	cast iron ball bearings increased clearances	2
Consumption measurement (Printing press)	offset ink lubricating high viscosity	cast iron bronze plain bearings large clearances	3
Ratio control (2 component plant)	polyol + isocyanate, adhesives, resin, silicon low lubricity medium viscosity	cast iron carbide plain bearings increased clearances	4
Batching control (lacquering plant)	clear lacquer, cavity waxes low lubricity medium viscosity	stainless steel carbide plain bearings increased clearances	5
Flow rate measurement (lacquering plant)	solvent lubricating low viscosity	stainless steel ball bearings minimal clearances	6

For fluids with a low viscosity and poor lubricity a hybrid ball bearing (with ceramic balls) is available for sizes VC 0.025, VC 0.04, VC 0.2 and VC 1.

Flow meters with hybrid ball bearing are available in cast iron (**series 7**) and stainless steel (**series 8**).

# Accuracy-characteristics

- The accuracy figures quoted by KRACHT refer to the geometric tooth volume  $V_{gz}$ , that is to say the percentage deviation applies to the current value in each case.
- The linearity error over the entire measuring range is  $< \pm 0.1 \%$
- Reproducibility of a measured value is  $< 0.1 \%$
- Accuracy checking forms part of quality inspection in every case.
- On request the result of the test will be documented in the form of an accuracy characteristic curve; an example relating to a series 1 VC 1 is given below.
- The accuracy values quoted by Kracht are confirmed by the DKD (German Calibration Service).

## Accuracy

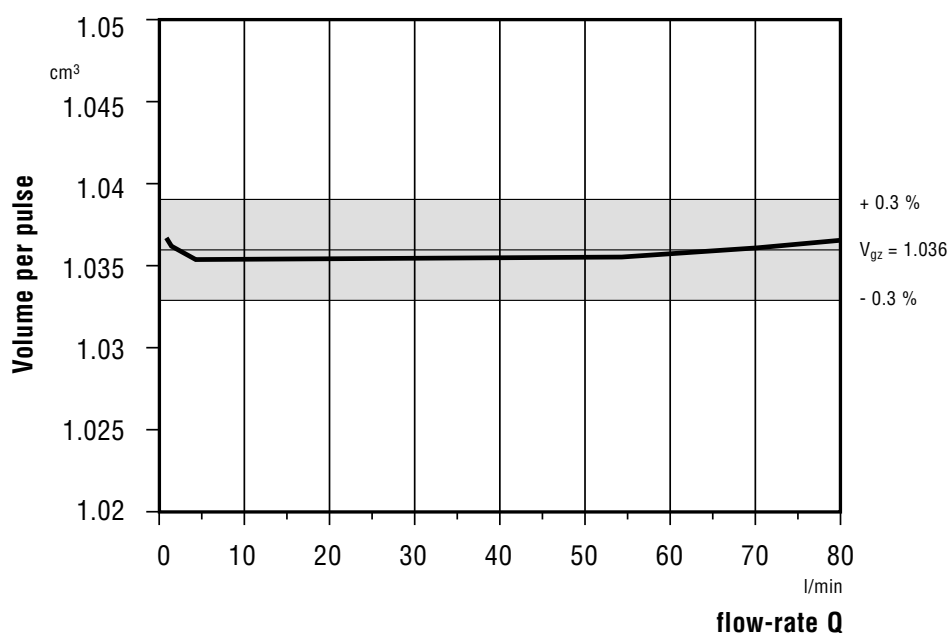

## Linearity

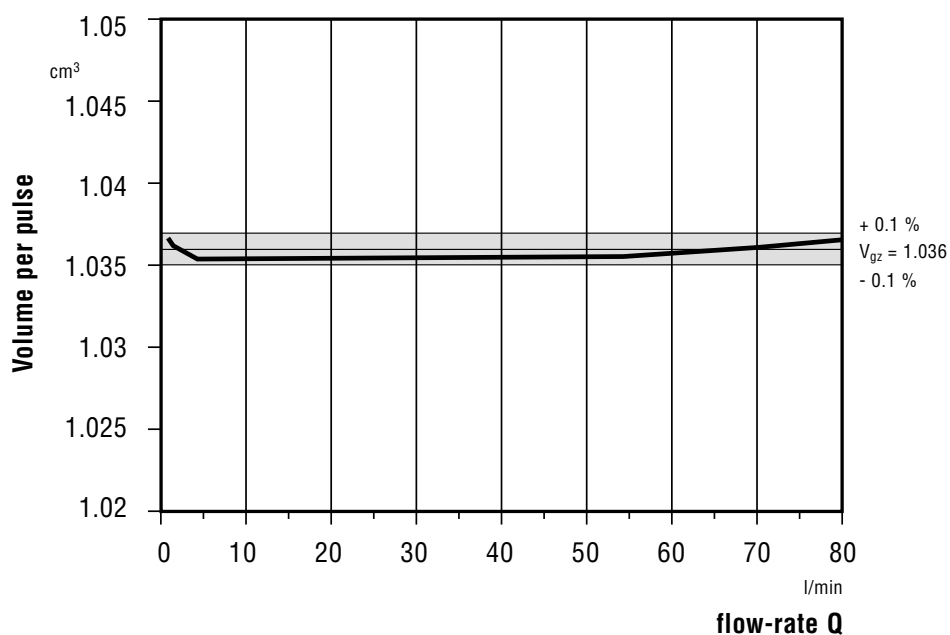

# Mechanical characteristics

## General characteristics

Design	gear motor	Flow direction	optional
Connection type	plate mounting / pipe connection	Viscosity	1...100,000 mm <sup>2</sup> /s, according to series
Mounting Position	optional	Max. pressure drop	$\Delta p_{\max} = 16 \text{ bar}$

		Sealing materials			
		TFE/P	FKM	EPDM	FEP
Ambient temperature		-10 °C – +80 °C	-15 °C – +80 °C	-30 °C – +80 °C	-30 °C – +80 °C
Medium temperature for standard version	Series 1, 2, 6, 7, 8	-10 °C – +120 °C	-15 °C – +120 °C	-30 °C – +120 °C	-30 °C – +120 °C
	Series 3, 4, 5	-10 °C – +80 °C	-15 °C – +80 °C	-30 °C – +80 °C	-30 °C – +80 °C
Medium temperature for high temperature version	Series 1, 2, 6, 7, 8	-10 °C – +150 °C	-15 °C – +150 °C	-30 °C – +130 °C	-30 °C – +150 °C
	Series 3, 4, 5	on request	on request	on request	on request
Medium temperature for  -version	Series 1, 2, 6, 7, 8	-10 °C – +80 °C	-15 °C – +80 °C	-30 °C – +80 °C	-30 °C – +80 °C
	Series 3, 4, 5	-10 °C – +80 °C	-15 °C – +80 °C	-30 °C – +80 °C	-30 °C – +80 °C

## Series selection/Summary of variants

Series	1	2	3	4	5	6	7	8
Material housing	cast iron GGG 40 (/79 GGG 60)	cast iron GGG 40	cast iron GGG 40	cast iron GGG 40	stainless steel 1.4404	stainless steel 1.4404	cast iron GGG 40	stainless steel 1.4404
Material gears	steel 1.7139	steel 1.7139	steel 1.7139	steel 1.7139	stainless steel 1.4462	stainless steel 1.4462	steel 1.7139	stainless steel 1.4462
Bearing	ball bearings	ball bearings	bronze plain bearings	carbide plain bearings	carbide plain bearings	stainless steel ball bearings	hybrid ball bearings	hybrid ball bearings
Connection	P	P	P	P	P/R	P/R	P	P/R
Max. perm. foreign particle size in the medium (µm)	20	30	50	30	30	20	20	20
Accuracy (from measuring value)	± 0.3 % at ≥ 20 mm <sup>2</sup> /s	± 0.5 % at ≥ 50 mm <sup>2</sup> /s	± 1 % at ≥ 100 mm <sup>2</sup> /s	± 0.5 % at ≥ 100 mm <sup>2</sup> /s	± 0.5 % at ≥ 100 mm <sup>2</sup> /s	± 0.3 % at ≥ 20 mm <sup>2</sup> /s	± 1 % at ≥ 20 mm <sup>2</sup> /s	± 1 % at ≥ 20 mm <sup>2</sup> /s

Nominal size	Starting point at [l/min]		Measuring range [l/min]						
0.025	0.001	0.008 – 2	–	–	–	0.02 – 2 *	0.008 – 2	0.008 – 2	0.008 – 2
0.04	0.004	0.02 – 4	–	–	–	–	0.02 – 4	0.02 – 4	0.02 – 4
0.1	0.008	0.04 – 8	–	–	–	–	–	–	–
0.2	0.01	0.16 – 16	0.16 – 16	–	0.16 – 16	0.16 – 16	0.16 – 16	0.16 – 16	0.16 – 16
0.4	0.01	0.2 – 40	–	–	0.2 – 30	–	–	–	–
1	0.02	0.4 – 80	0.4 – 80	0.6 – 40	0.3 – 60	0.3 – 60	0.4 – 80	0.4 – 80	0.4 – 80
3	0.03	0.6 – 160	0.6 – 160	–	0.6 – 100	0.6 – 100	0.6 – 160	–	–
5	0.04	1 – 250	1 – 250	1.2 – 80	1 – 160	1 – 160	1 – 250	–	–

10 see data sheet VC 10

\* Measuring accuracy ± 3 %; Linearity ± 1.5 %

## Operating characteristics

Nominal size	geom. tooth-volume $V_{gZ}$ cm <sup>3</sup>	max. operating pressure		Peak pressure		Sound pressure level $L_A$ dB (A)	Resolution Imp/l l
		Standard-version $p_{\max}$ bar	High pressure version (/79) $p_{\max}$ bar	Standard-version $\hat{p}$ bar	High pressure version (/79) $\hat{p}$ bar		
0.025	0.025	400	–	480	–	< 60	40,000.00
0.04	0.04	400	–	480	–	< 60	25,000.00
0.1	0.1	400	–	480	–	< 60	10,000.00
0.2	0.245	400	–	480	–	< 60	4,081.63
0.4	0.4	400	–	480	–	< 70	2,500.00
1	1.036	400	–	480	–	< 70	965.25
3	3.000	315	400	350	480	< 70	333.33
5	5.222	315	400	350	480	< 72	191.50
10							see data sheet VC 10

# Type code

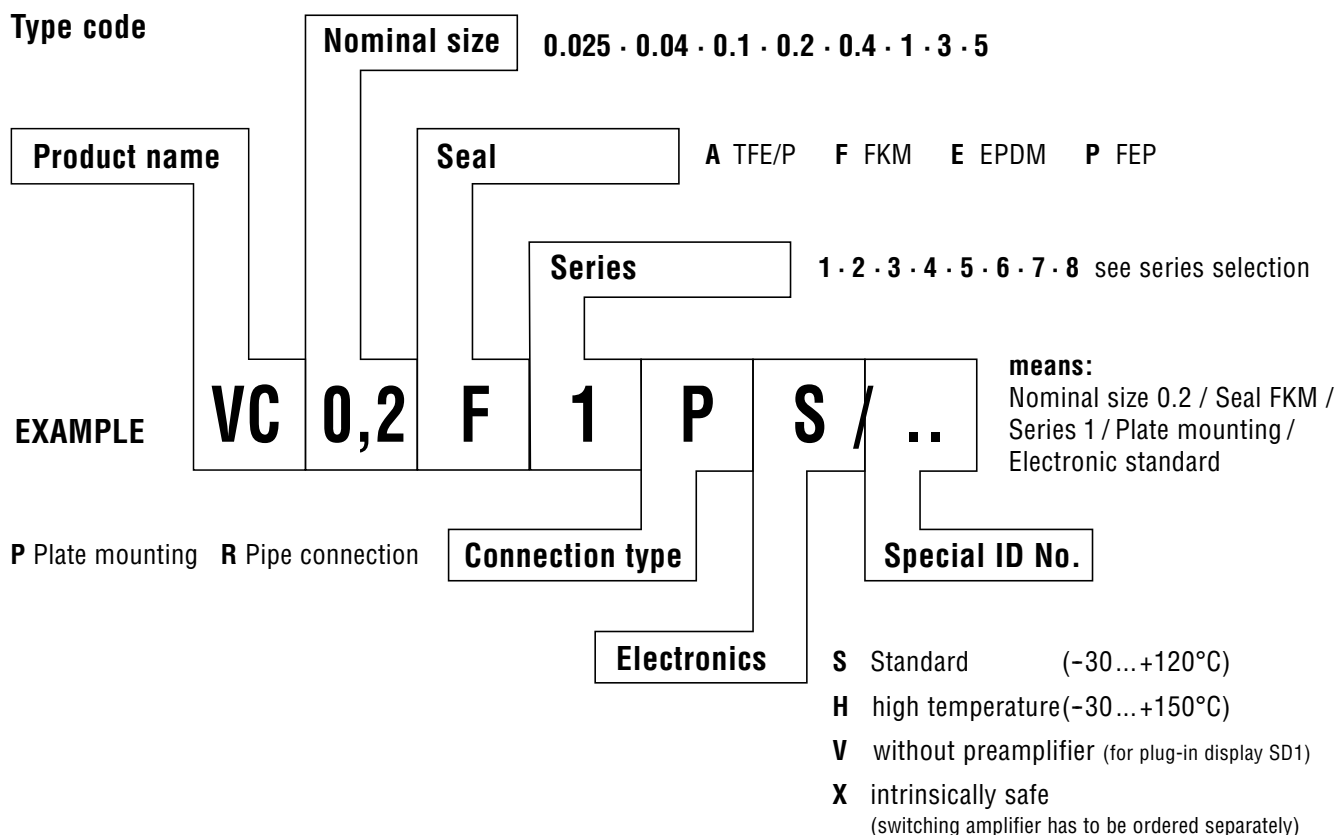

## Special versions

No.	Series	Description
55	1-8	Version with aluminium connection box and preamplifier VV12 with Cannon plug
64	1	<b>Skydrol version</b> with Aluminium connection box with Cannon plug, housing and cover nickel plated
65	1	with separate preamplifier and Cannon plug, for ambient temperature > 80 °C
71	1-8	Version with Hirschmann connector and round connector M12 x1
74	1-8	Version with Hirschmann connector and preamplifier VV12 for 12 Volt power supply (10.5 – 16 Volt)
79	1	VC 3 and VC 5 in high pressure version (400 bar)
83	1-8	Version with aluminium connection box and cable gland incl. switching amplifier (no ex-protection), for ambient temperature > 80 °C
99	1	VC 3 and VC 5 in high pressure version (400 bar) <b>Skydrol resistant</b> , with aluminium connection box and Cannon plug, housing and cover nickel plated

# Electrical characteristics

## Electrical connection

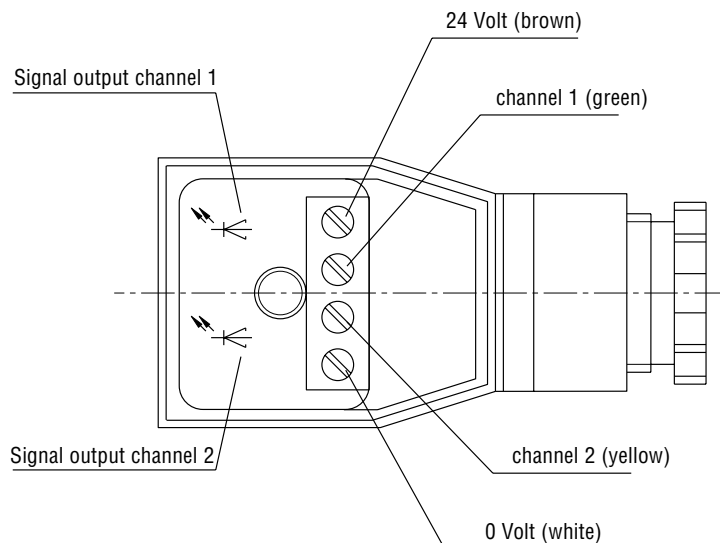

## Electrical characteristics

Number of measuring channels	2	Pulse offset between two channels	$90^\circ \pm 30^\circ$
Operating voltage	$U_{op} = 12 \dots 30$ VDC polarized	Power requirement	$P_{b\max} = 0.9$ W
Pulse amplitude	$U_{out} \geq 0.8 U_{op}$	Output power/channel	$P_{a\max} = 0.3$ W short-circuit-proof
Pulse shape with symm. output signal	square wave pulse duty factor/channel $1:1 \pm 15\%$	Degree of protection	IP 65 DIN 40050
Signal output	PNP (NPN on request)		

## Signal-characteristics

### Channel I

- A rising edge
- B one pulse (corr. to flow rate of geom. tooth volume  $V_{gz}$ )
- C falling edge
- D ON phase
- E OFF phase
- F pulse duty factor  $1:1 \pm 15\%$

### Channel II

- G channel offset
- H flow direction 1
- K Reversal of flow direction
- J flow direction 2

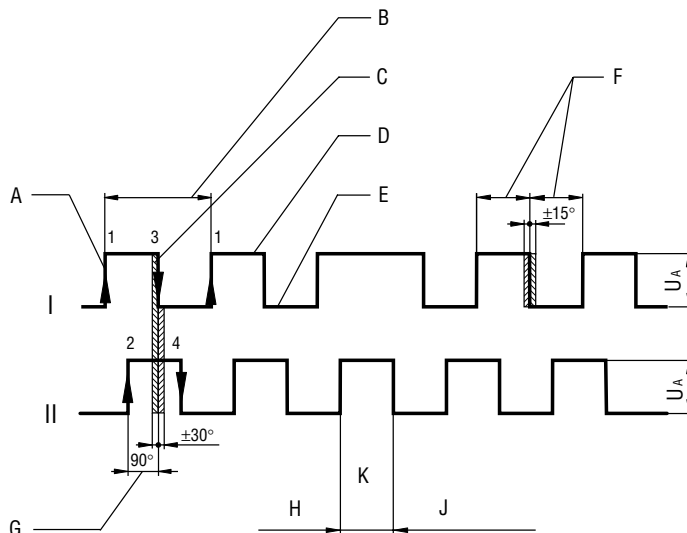

# Explosion-proof design (ATEX)

## Principle of operation

- All volume counters are available in explosion-proof design according to ATEX.
- The explosion-proof design consists of the volume counter (intrinsically safe electrical apparatus) and the switching amplifier K 130 (associated electrical apparatus).
- The type of protection „intrinsic safety“ applies to this construction.
- The volume counter is installed in the potentially explosive atmosphere.
- The mounting of the switching amplifier K 130 is carried out in the safe area.
- Volume counter and switching amplifier are electrically connected to each other. The switching amplifier evaluates the sensor signals and converts them to square-wave signals.
- Without switching amplifier, the volume counter must not be operated in the potentially explosive atmosphere.
- Cable lengths of up to 400 m are possible between volume counter and switching amplifier.
- LED's for monitoring line breaks / short circuits, channel switching state and power supply are located on the switching amplifier.

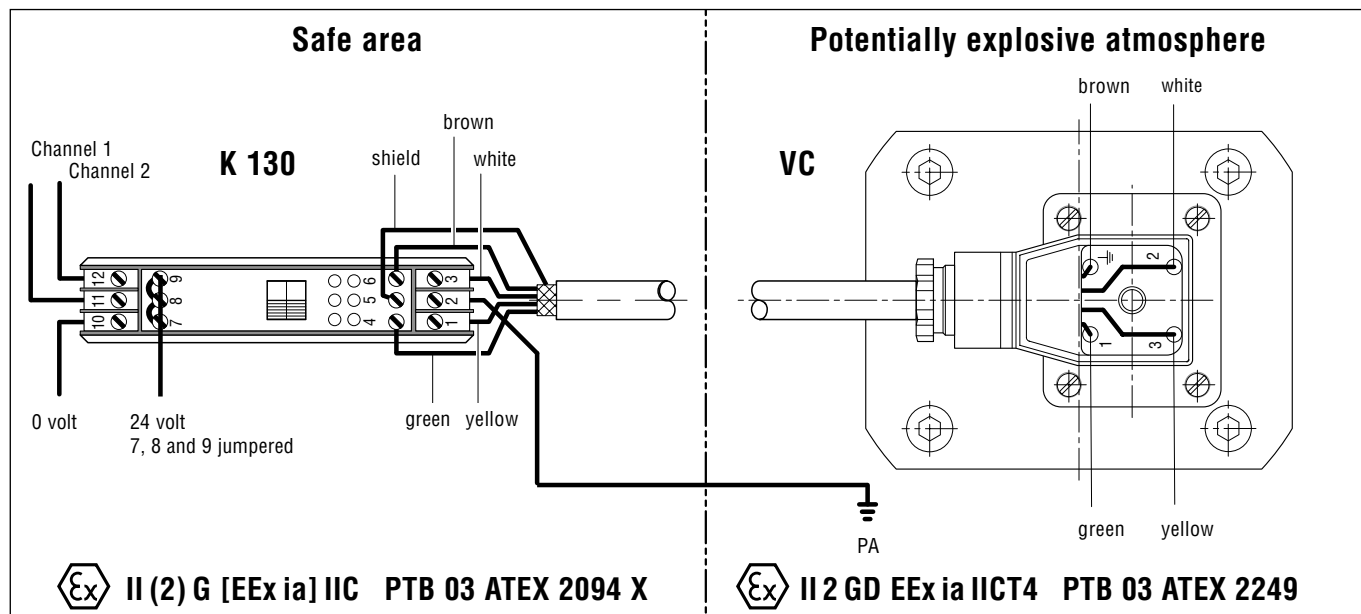

## Technical data of switching amplifier K-130/3-E-10

### Power supply

Supply voltage cl. 7 (L+), cl. 10 (L-) DC 24 volt ± 20 %  
 Ripple content white Wss < 10 %

### Outputs (non-intrinsically safe)

#### Characteristics cl. 9, 12, 8, 11

Electronics outputs electrically isolated via optoelectronic coupler  
 Short-circuit current approx. 25 mA  
 Signal level 1-signal 0.8 x supply voltage with RL > 2 k ohm  
 Signal level 0-signal inhibited output, residual current < 10 uA

### Ambience conditions

Minimum limiting temperature 248 K (-25 °C)  
 Maximum limiting temperature 333 K (+60 °C)

### Mechanics

Dimensions 107.5 x 92 x 22 mm  
 Connection possibility can be snapped on a 35 mm mounting channel DIN 46277  
 Weight approx. 150 g



# Pressure drop

Series 1, 2, 6, 7 and 8 Parameter: Viscosity (mm<sup>2</sup>/s)

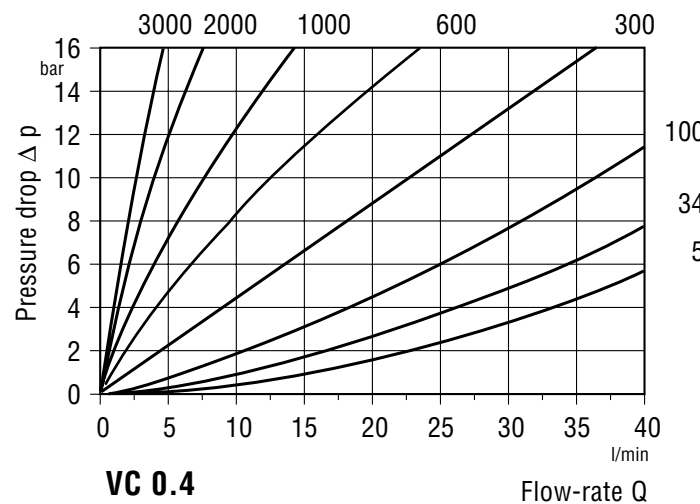
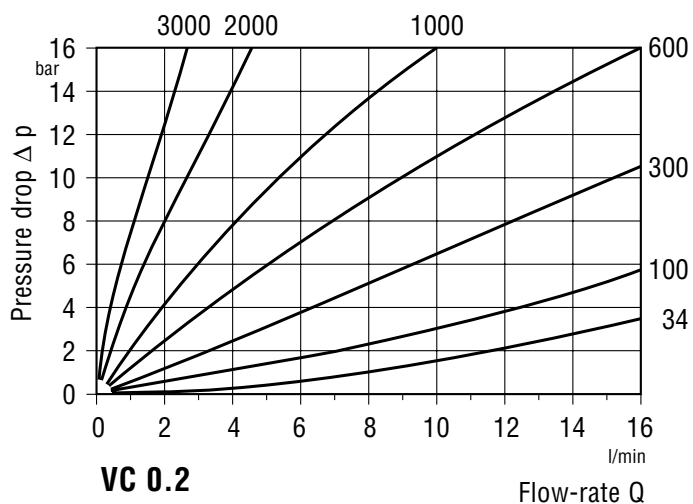
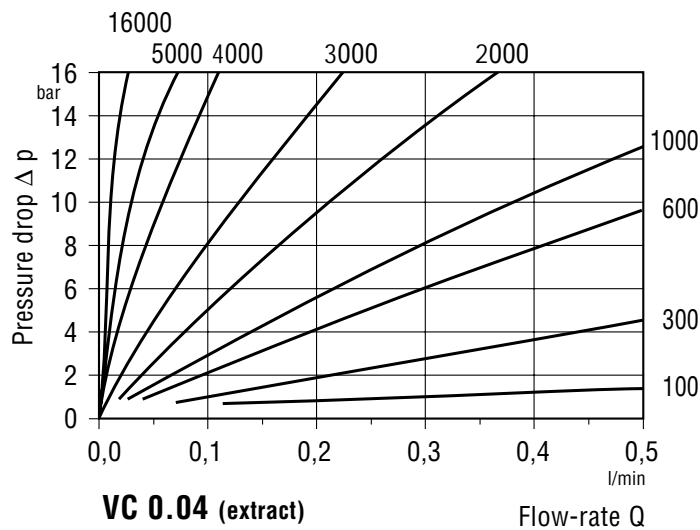
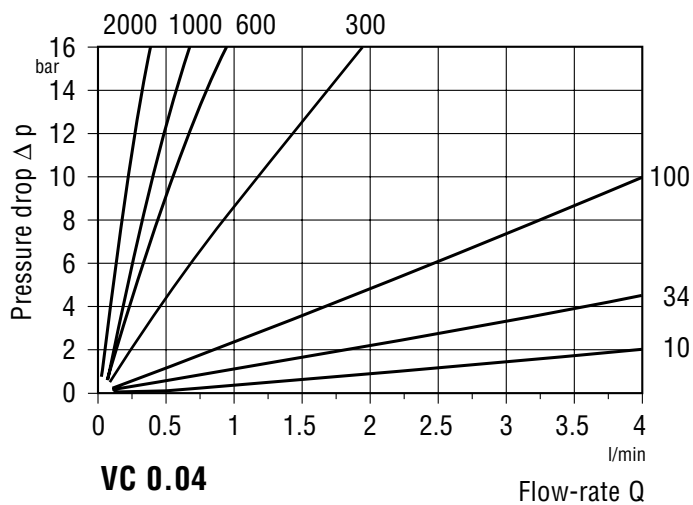
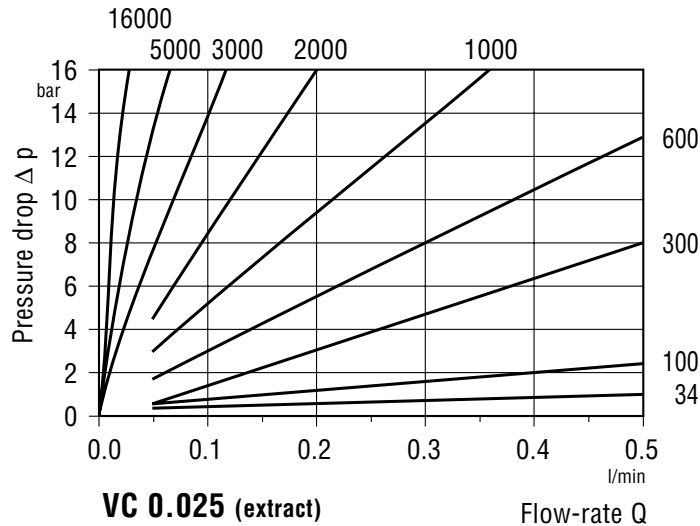
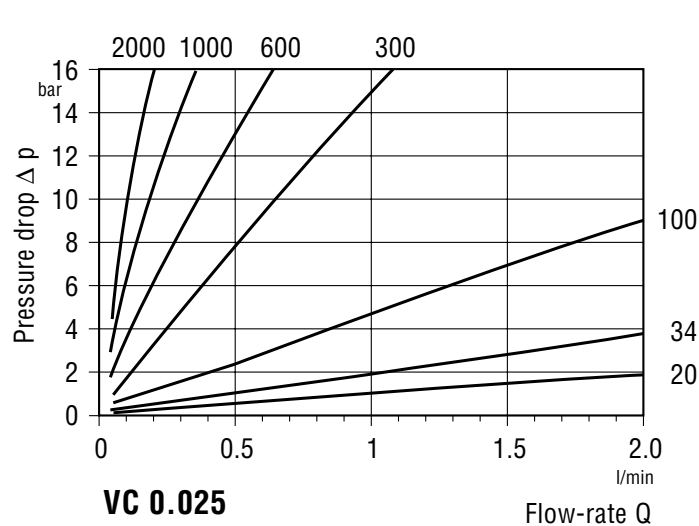

# Pressure drop

## Series 1, 2, 6, 7 and 8 Parameter: Viscosity (mm<sup>2</sup>/s)

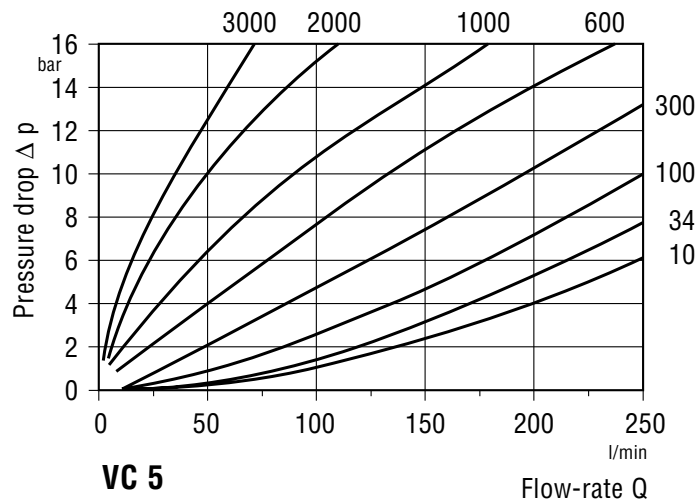
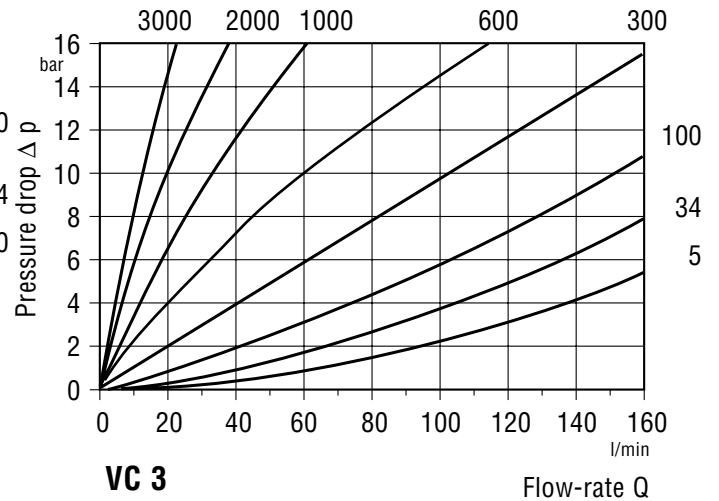
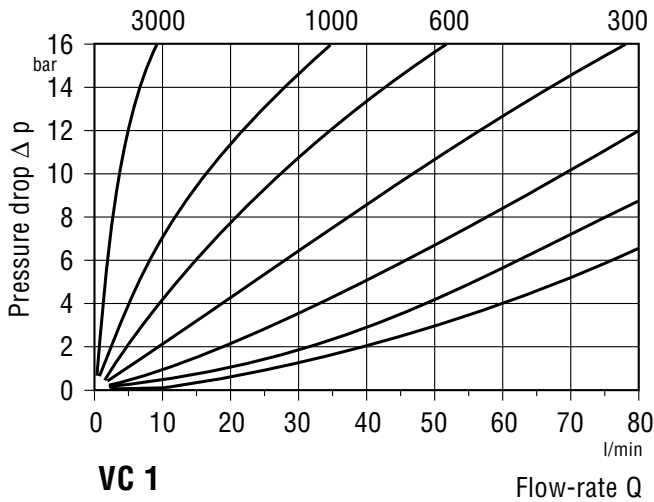

## Series 3 Parameter: Viscosity (mm<sup>2</sup>/s)

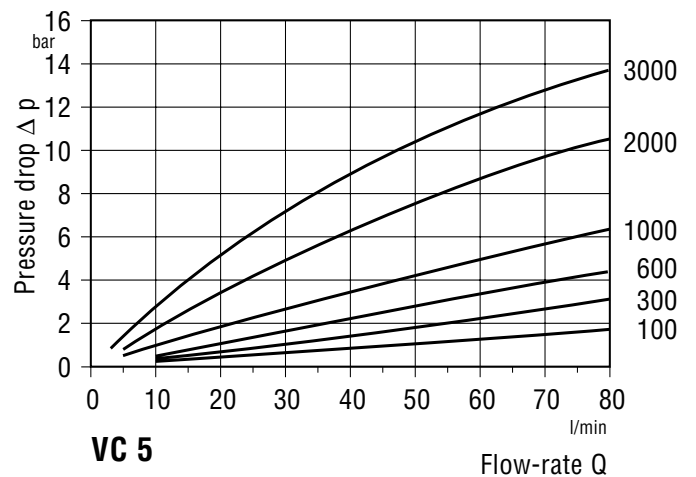
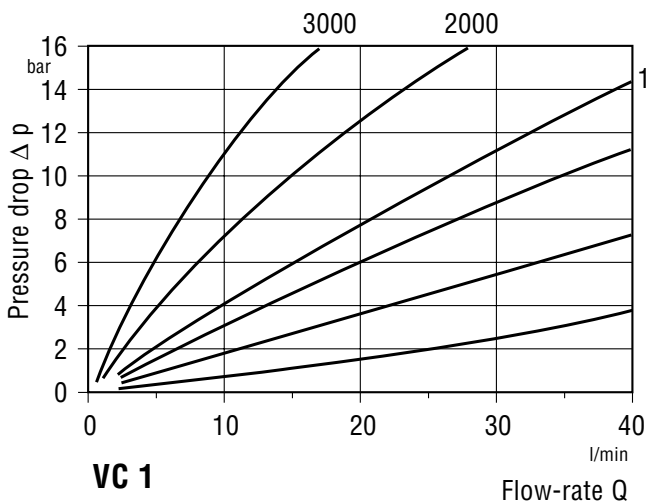

# Pressure drop

**Series 4/5** Parameter: Viscosity (mm<sup>2</sup>/s)

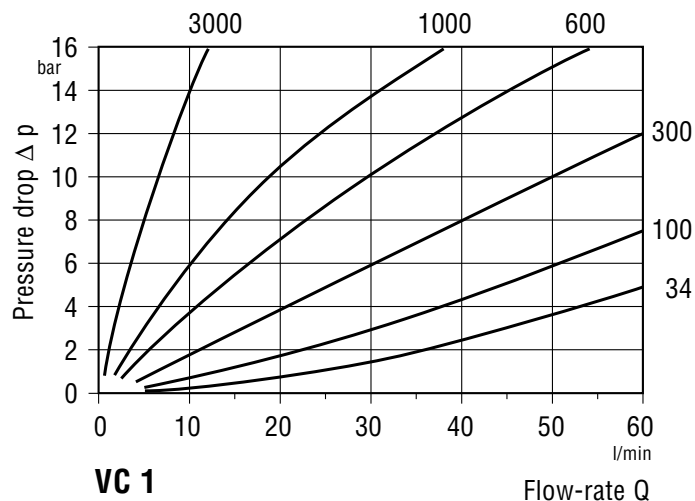
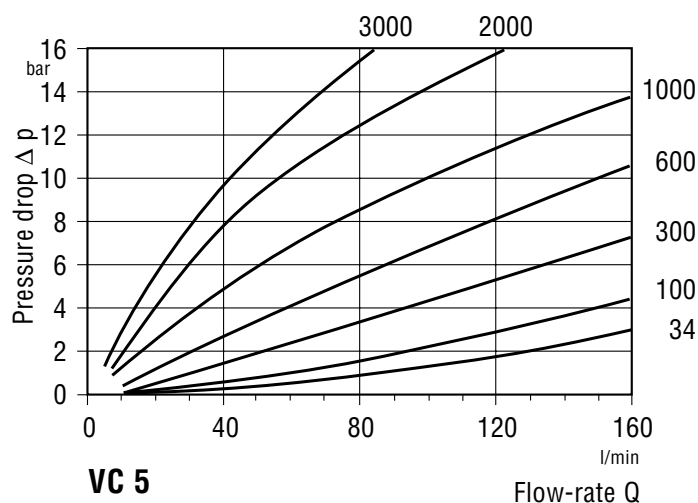
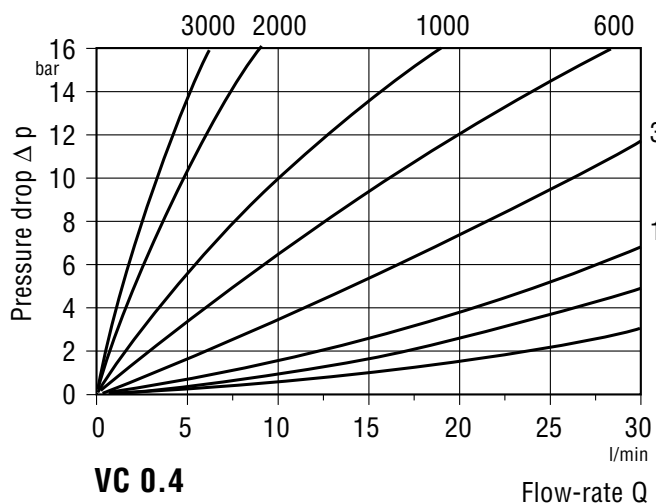
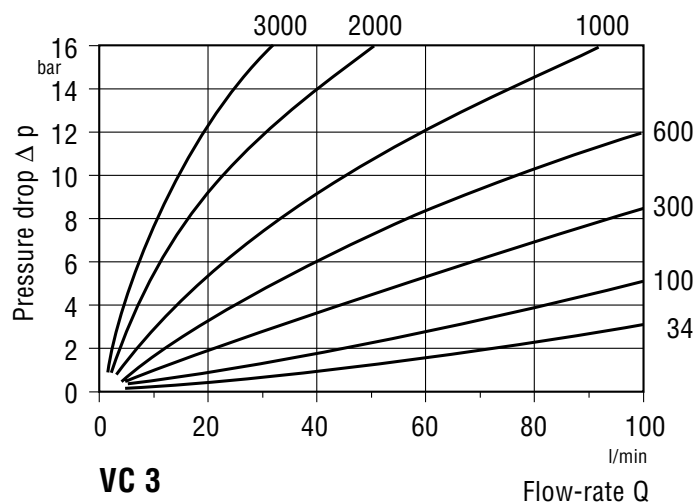
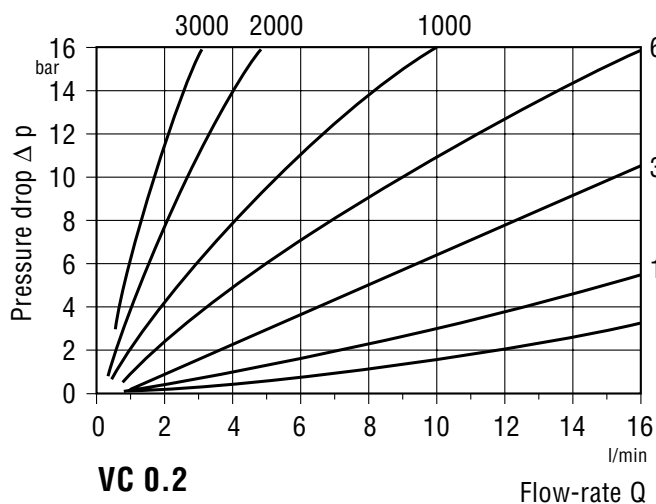

# Dimensions

## Series 1, 2, 3, 4, 7 – Connection type P

Nominal size	Available series	Weight kg	Tightening torque Nm	Dimensions in mm											
				m	M <sub>A</sub>	A	C	D	F	G <sub>s</sub>	G <sub>H</sub>	J	K	L	M
VC 0.025	1	1.8	14	85	10	60	50	101	114	–	70	40	20	6.5	M 6
VC 0.04	1, 7	2	14	85	9	60	56	107	120	–	70	40	20	6.5	M 6
VC 0.1	1	2.3	14	85	10	60	65	116	129	–	70	40	20	6.7	M 6
VC 0.2	1, 2, 4, 7	2	14	85	13	60	57	108	121	–	70	40	20	9	M 6
VC 0.4	1, 4	3.7	35	100	17	90	63	114	127	–	80	38	34	16	M 8
VC 1	1, 2, 3, 4, 7	5.2	35	120	13	95	72	123	136	15.5	84	72	35	16	M 8
VC 3	1, 2, 4	9	120	170	18	120	89	140	153	46.5	46	95	50	25	M 12
VC 5	1, 2, 3, 4	13	120	170	22	120	105	156	169	46.5	46	95	50	25	M 12
VC 10	see data sheet VC 10														

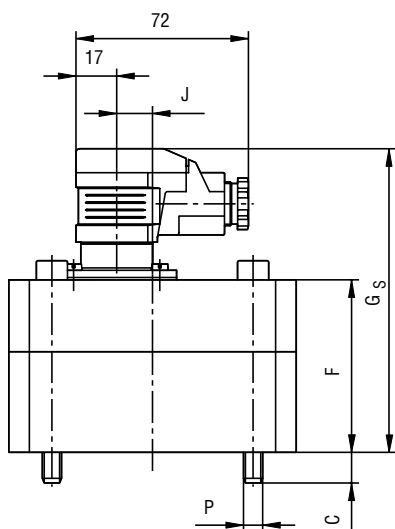

**Version S and Version X**

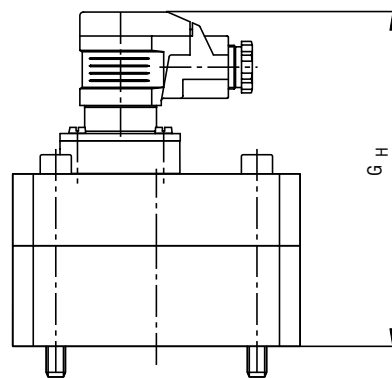
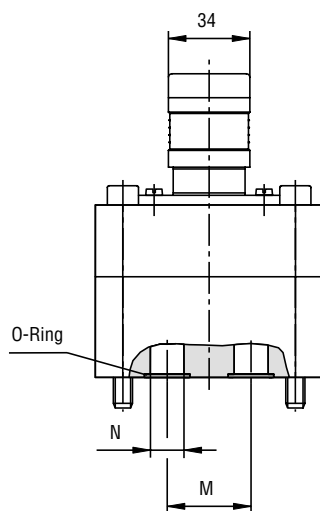

**Version H**

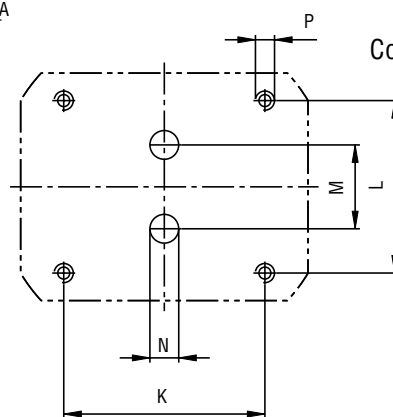
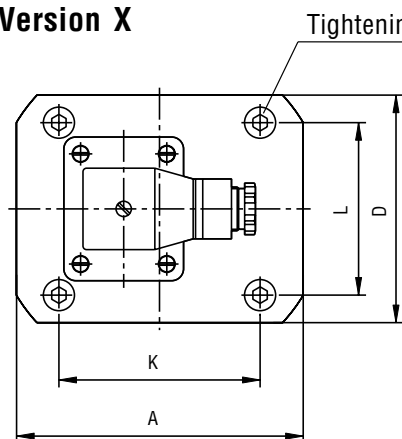

Connection dimensions

# Dimensions

## Series 1 – High pressure version (/79)

Nominal size	Weight kg	Dimensions in mm										
		m	C	D	F	G <sub>s</sub>	G <sub>H</sub>	J	K	L	M	N
VC 3	16.3	24.5	180	99	150	163	46.5	46	95	50	25	M12
VC 5	18.9	22	180	115	166	179	46.5	46	95	50	25	M12

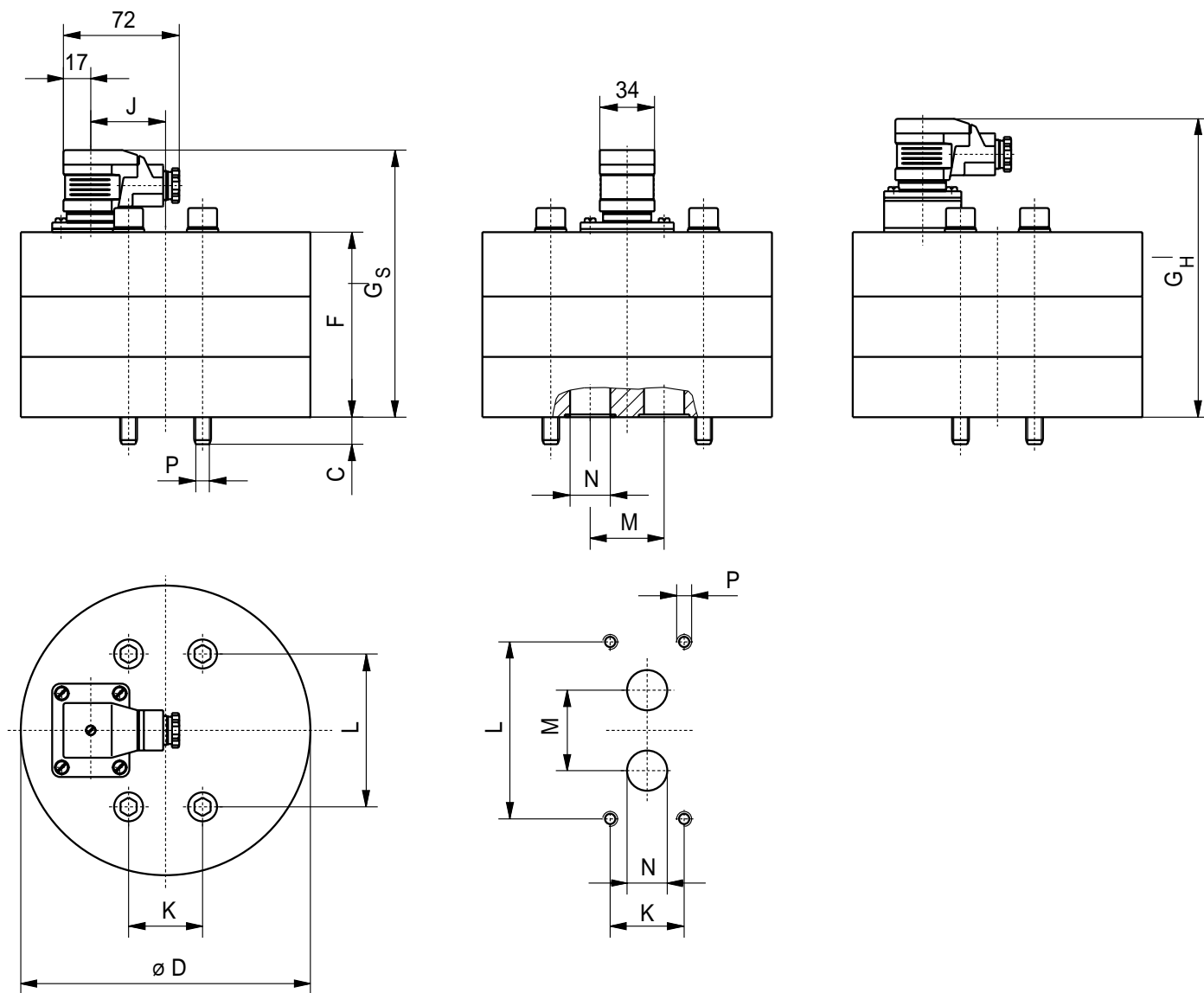

# Connection plate (cast iron) for VC 3/79 and VC 5/79 (high pressure)

with side SAE flange connection

Ordering code	Weight kg	Dimensions in mm															
		m	B	C	D	E	F	G	K	L	M	N	P	R	a	b	e
MVC 5 V1 E09*	14.2	150	90	180	110	110	M8/15 t	46	95	50	25	M12/24 t	40	57.2	27.8	25	M12/24 t

\* fits for VC 3 and VC 5

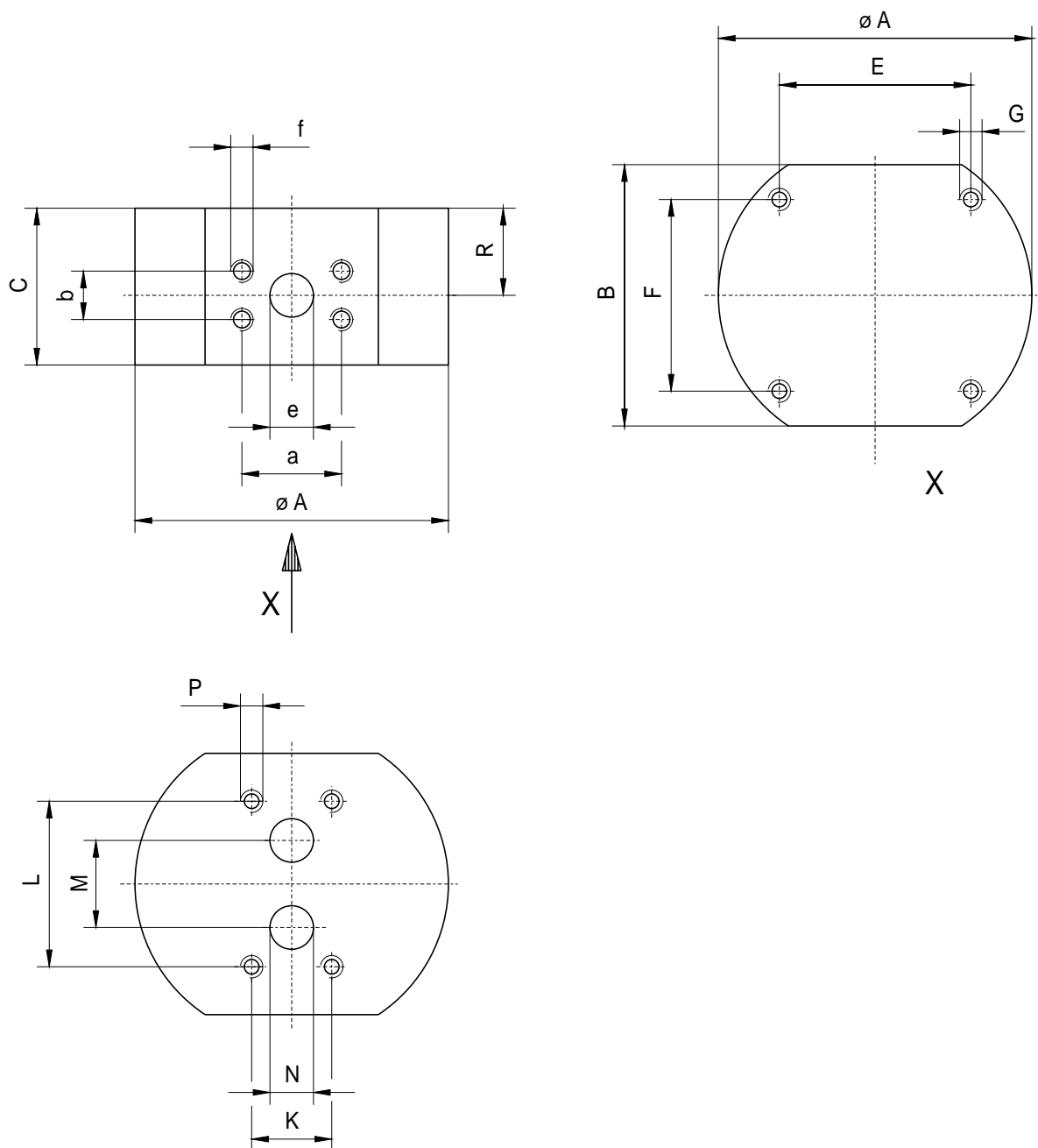

# Dimensions

## Series 5, 6 and 8 (stainless steel) – Connection type P

Nominal size	Available series	Weight kg	Tightening torque Nm	Dimensions in mm										
				m	M <sub>A</sub>	C	D	F	G <sub>s</sub>	G <sub>H</sub>	J	K	L	M
VC 0.025	5, 6, 8	3	14	15	94	55	106	119	–	70	40	20	6.5	M 6
VC 0.04	6, 8	3	14	9	94	56	107	120	–	70	40	20	6.7	M 6
VC 0.2	5, 6, 8	3.1	14	13	94	57	108	121	–	70	40	20	9	M 6
VC 1	5, 6, 8	7	35	13	124	72	123	136	15.5	84	72	35	16	M 8
VC 3	5, 6	15.9	120	21	170	89	140	153	46.5	46	95	50	25	M 12
VC 5	5, 6	18.7	120	25	170	105	156	169	46.5	46	95	50	25	M 12

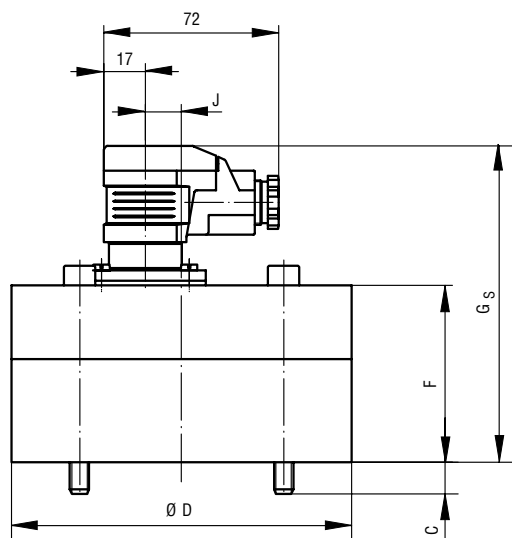

**Version S  
and Version X**

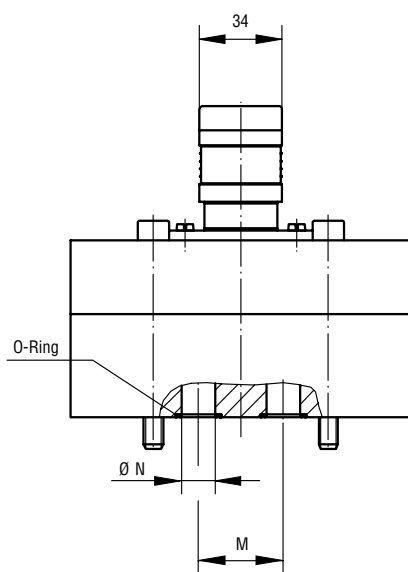

**Version H**

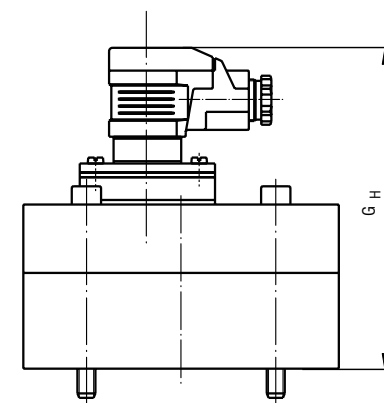

**Connection dimensions**

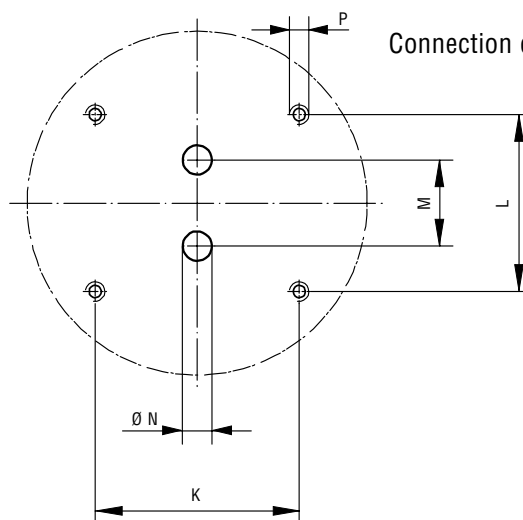
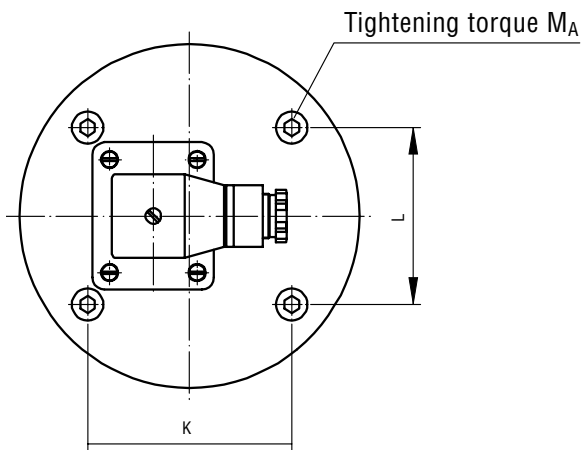

# Dimensions

## Series 5, 6 and 8 – Connection type R

Nominal size	Available series	Weight kg	Dimensions in mm												
			m	A	B	C	D	E	F	G <sub>s</sub>	G <sub>H</sub>	H	J	K	L
VC 0.025	5, 6, 8	3	G 1/8	9	17	94	90	55	106	119	15	–	70	40	6.7
VC 0.04	6, 8	3	G 1/4	13	21	94	90	56	107	120	15	–	70	40	6.7
VC 0.2	5, 6, 8	3.1	G 3/8	13	25	94	90	57	108	121	16	–	70	40	6.7
VC 1	5, 6, 8	7	G 1/2	15	29	124	120	72	123	136	22	15.5	84	72	9
VC 3	5, 6	15.9	G 1	19	42	170	162	89	140	153	30	46.5	46	50	13
VC 5	5, 6	18.7	G 1	19	42	170	162	105	156	169	30	46.5	46	50	13

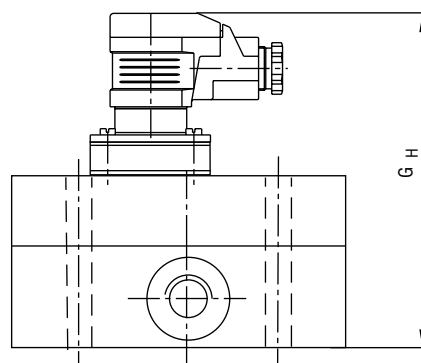
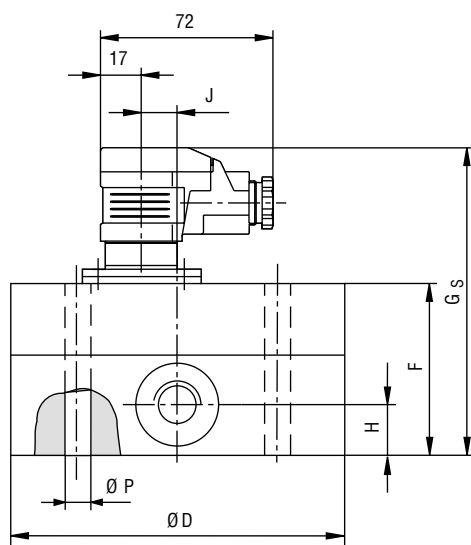

**Version S and Version X**

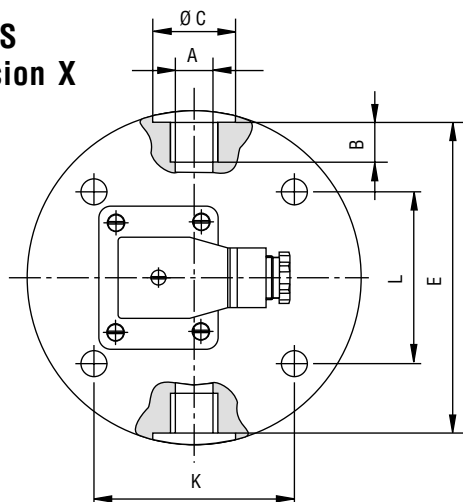

**Version H**



# Connection plates (cast iron)

## with side threaded connection

Ordering code	Weight kg	Dimensions in mm																		
		m	A	B	C	E	F	G	H	J	K	L	M	N	P	R	c	d	e	f
MVC 0.2 R 3 B 05*	1.8	85	90	35	65	76	7	11	7	70	40	20	6.5	M 6/14 t	17	0.7	25	G $\frac{3}{8}$	13	
MVC 0.2 R 3 C 05*	1.7	85	90	35	65	76	7	11	7	70	40	20	6.5	M 6/14 t	17.5	0.7	29	G $\frac{1}{2}$	15	
MVC 0.4 R 1 C 09	2.7	100	110	37	86	96	7	11	7	80	38	34	16	M 8/18 t	18.5	0.7	29	G $\frac{1}{2}$	15	
MVC 0.4 R 1 D 09	2.9	100	110	42	86	96	7	11	7	80	38	34	16	M 8/18 t	21	1	36	G $\frac{3}{4}$	17	
MVC 1 R 2 C 05	2.9	100	120	37	80	106	7	11	7	84	72	35	12	M 8/18 t	17.5	0.7	29	G $\frac{1}{2}$	15	
MVC 1 R 3 D 05	4	120	120	42	80	106	7	11	7	84	72	35	13	M 8/18 t	21	1	36	G $\frac{3}{4}$	17	
MVC 1 R 2 E 05	4.9	100	120	65	80	106	7	11	8	84	72	35	13	M 8/18 t	32.5	1	42	G1	19	
MVC 5 R 2 E 05**	14	160	165	80	140	145	9	15	9	46	95	50	25	M12/24 t	28	1	42	G1	19	
MVC 5 R 2 G 09**	17.8	170	165	100	140	145	9	15	9	46	95	50	25	M12/24 t	42	1	58	G1 $\frac{1}{2}$	23	
MVC 10 R 2 G 05	28	200	215	100	176	191	11	18	11	64	125	70	38	M16/25 t	35	1	58	G1 $\frac{1}{2}$	23	

\* fits for VC 0.025, VC 0.04, VC 0.1 and VC 0.2

\*\* fits for VC 3 and VC 5

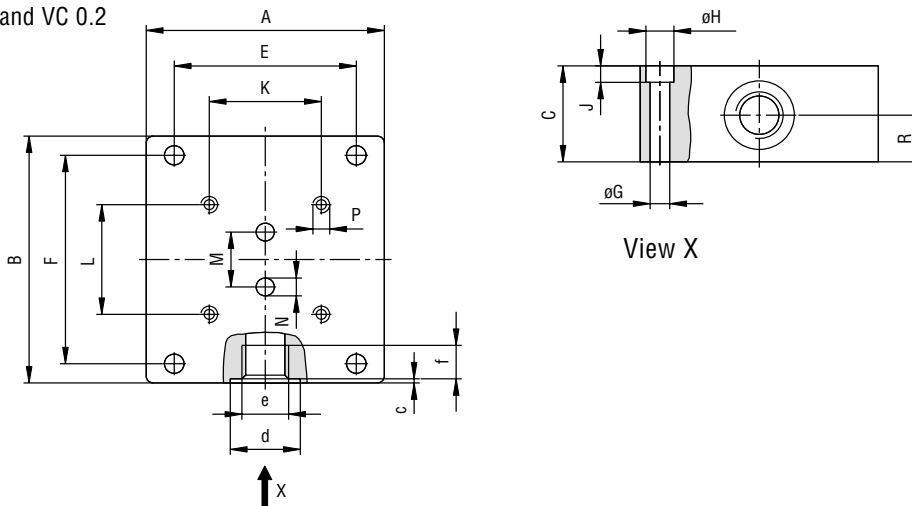

## with side SAE flange connection

Ordering code	Weight kg	Dimensions in mm																		
		m	A	B	C	E	F	G	H	J	K	L	M	N	P	R	a	b	e	f
MVC 5 V 2 E 05**	14	160	165	80	140	145	9	15	9	46	95	50	25	M12/24 t	40	57.2	27.8	25	M12/24 t	
MVC 5 V 1 F 09	15.1	160	165	90	140	145	9	15	9	46	95	50	25	M12/24 t	50	66.7	31.8	31.5	M14/25 t	
MVC 10 V 2 G 05	29	200	215	100	176	191	11	18	11	64	125	70	38	M16/25 t	50	79.4	36.5	32	M16/25 t	

\*\* fits for VC 3 and VC 5

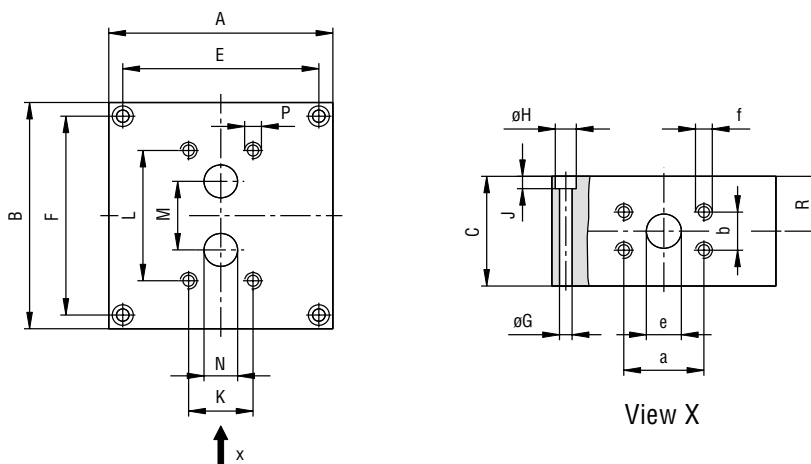

# Connection plates (cast iron)

## with rear threaded connection

Ordering code	Weight kg	Dimensions in mm																			
		m	A	B	C	E	F	G	H	J	K	L	M	N	P	R	c	d	e	f	
<b>MVC 0.2 R 3 B 04*</b>	1.6	85	90	35	65	76	7	11	7	70	40	20	6.5	M 6/14 t	28	0.7	25	G 3/8	13		
<b>MVC 0.4 R 1 C 08</b>	2.5	100	110	37	86	96	7	11	7	80	38	34	16	M 8/18 t	46	0.7	29	G 1/2	15		
<b>MVC 0.4 R 1 D 08</b>	2.9	100	110	42	86	96	7	11	7	80	38	34	16	M 8/18 t	52	1	36	G 3/4	17		
<b>MVC 1 R 2 C 04</b>	2.7	100	120	37	80	106	7	11	7	84	72	35	12	M 8/18 t	50	0.7	29	G 1/2	15		
<b>MVC 5 R 2 E 04**</b>	9.6	160	165	55	140	145	9	15	9	46	95	50	25	M12/24 t	55	1	42	G1	19		
<b>MVC 10 R 2 G 04</b>	15	200	215	55	176	191	11	18	11	64	125	70	38	M16/25 t	72	1	58	G1 1/2	23		

\* fits for VC 0.025, VC 0.04, VC 0.1 and VC 0.2    \*\* fits for VC 3 and VC 5

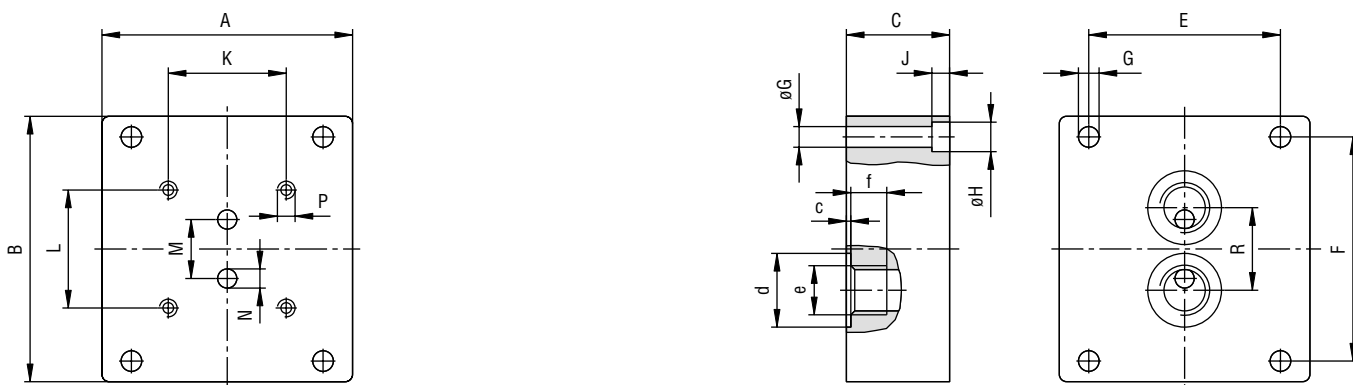

## with rear SAE flange connection

Ordering code	Weight kg	Dimensions in mm																	
		m	A	B	C	E	F	G	H	J	K	L	M	N	P	R	a	b	e
<b>MVC 5 V 2 E 04**</b>	9.5	160	165	55	140	145	9	15	9	46	95	50	25	M12/24 t	80	57.2	27.8	25	M12/24 t
<b>MVC 10 V 2 G 04</b>	16	200	215	55	176	191	11	18	11	64	125	70	38	M16/25 t	100	79.4	36.5	32	M16/25 t

\*\* fits for VC 3 and VC 5

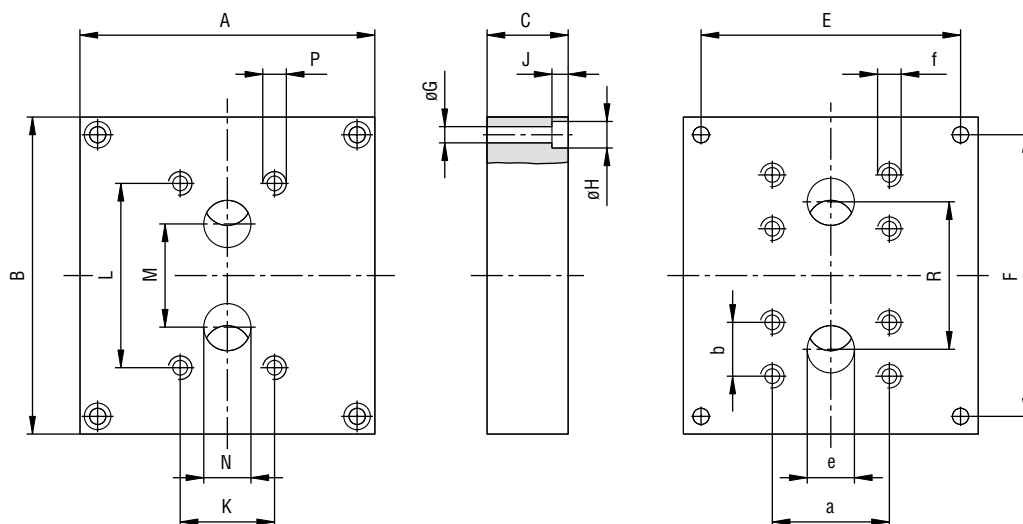

# Connection plates (Stainless steel)

## with side threaded connection

Ordering code	Weight kg	Dimensions in mm														
		m	B	D	C	E	G	H	J	K	L	M	N	P	R	e
<b>MVC 0.2 R4 B11*</b>	1.7	85	94	35	75	7	11	7	70	40	20	6.5	M6/14 t	18	G $\frac{3}{8}$	13
<b>MVC 1 R3 C11</b>	3.2	116	124	37	100	9	15	9	84	72	35	12	M8/18 t	19.5	G $\frac{1}{2}$	15
<b>MVC 1 R2 D11</b>	3.5	116	124	42	100	9	15	9	84	72	35	12	M8/18 t	21	G $\frac{3}{4}$	17
<b>MVC 5 R2 E11**</b>	13.9	158	170	80	140	9	15	9	46	95	50	25	M12/24 t	52	G1	19
<b>MVC 5 R2 G11**</b>	17.9	158	170	105	140	9	15	9	46	95	50	25	M12/24 t	63	G $1\frac{1}{2}$	23

\* fits for VC 0.025 VC 0.04 and VC 0.2

\*\* fits for VC 3 and VC 5

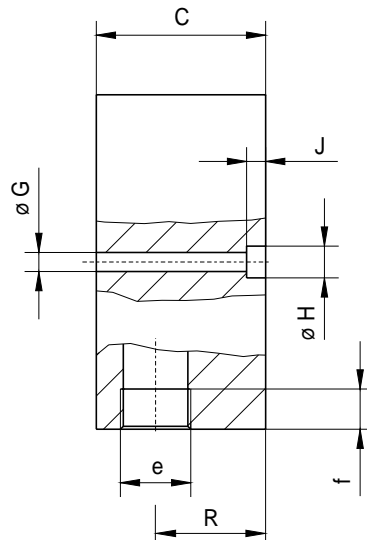
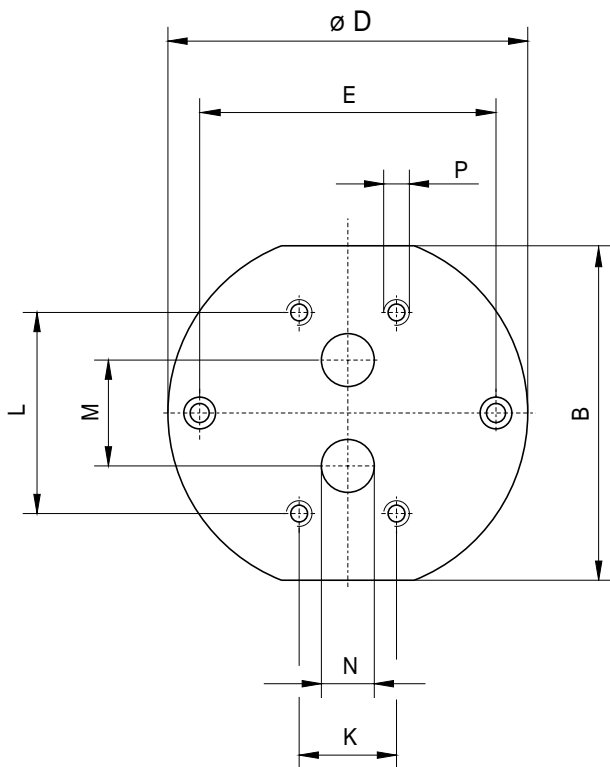

## Overview of our complete program

### Transfer pumps

Transfer pumps for lubricating oil supply equipment, low pressure filling and feed systems, dosing and mixing systems.

### Flow Measurement

Gear and turbine flow meters and electronics for volume and flow metering technology in hydraulics, processing and laquering technology.

### Mobile hydraulics

Single and multistage high pressure gear pumps, hydraulic motors and valves for construction machinery, vehicle-mounted machines.

### Industrial hydraulics

Cetop directional control and proportional valves, hydraulic cylinders, pressure, quantity and stop valves for pipe and slab construction, hydraulic accessories for industrial hydraulics (mobile and stationary use).

With our decades of experience, we are at your side, world-wide, for the professional mastery of specific applications and complete solutions in hydraulics and process technology.



VC.e.04.05